

MSRIH

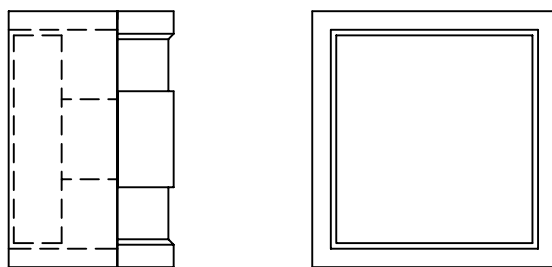

SHAPES

MH

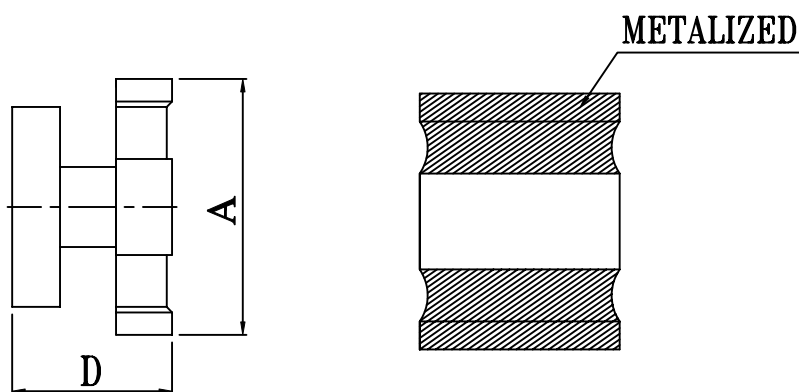

SRI

Fig1

Fig2

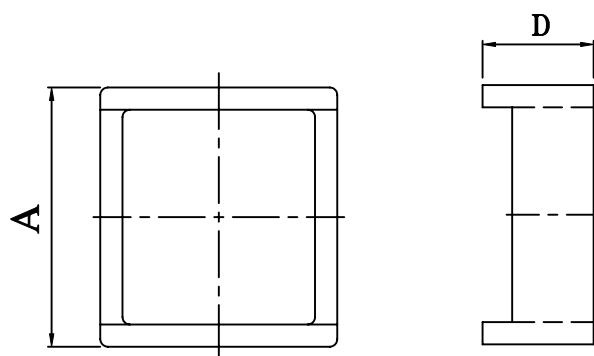
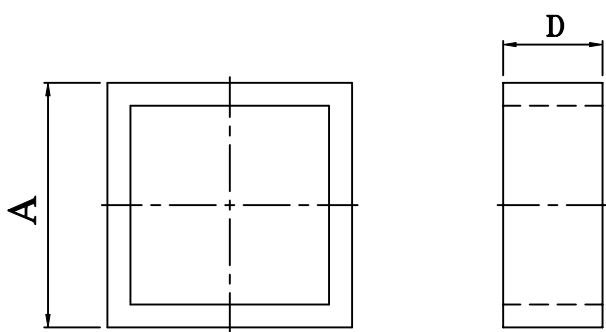

MATERIAL: Ni-Zn: E9H

DIMENSIONS OF MAIN PRODUCTS (UNIT: mm)

ITEM		A	D	Fig
MSRIH 3.3×3.3×1.9	MH 3.2×2.5×1.9	3.2±0.1	1.9±0.15	
	SRI 3.3×1.3	3.3±0.1	1.3±0.1	1
MSRIH 3.5×3.2×1.8	MH 3.2×2.7×1.8	3.2±0.1	1.8±0.1	
	SRI 3.5×3.2×1.5	3.5±0.1	1.5±0.1	2



YENG TAT ELECTRONICS CO.,LTD.